

(No Model.)

F. C. BEARD.
DRIVER FOR LATHES.

No. 280,119.

Patented June 26, 1883.

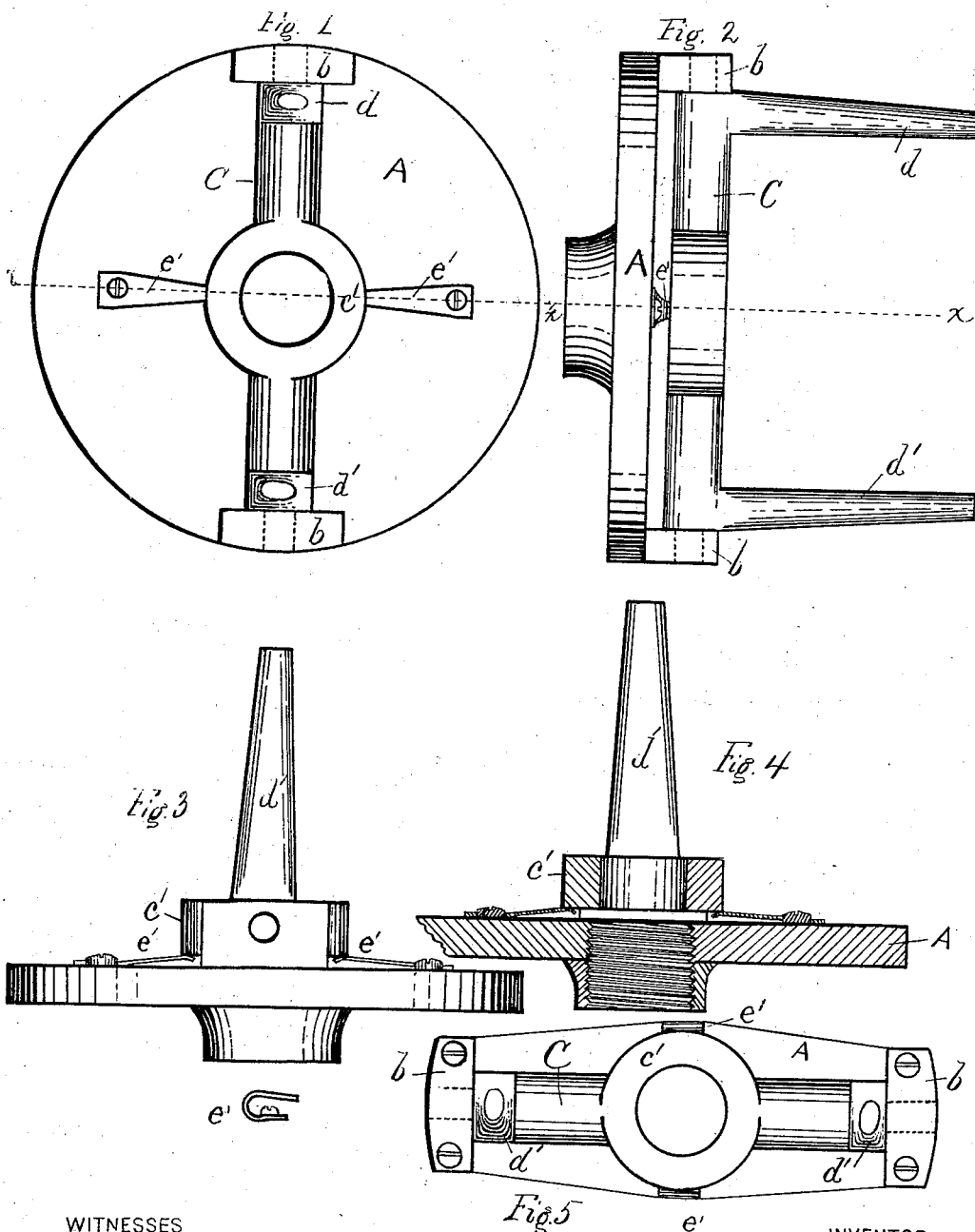

WITNESSES

Chas. R. Abell
Henry J. Sanders

INVENTOR

Frederick C. Beard,
John J. Halsted & Son ATTORNEYS.

UNITED STATES PATENT OFFICE.

FREDERICK C. BEARD, OF AURORA, ILLINOIS.

DRIVER FOR LATHES.

SPECIFICATION forming part of Letters Patent No. 280,119, dated June 26, 1883.

Application filed March 19, 1883. (No model.)

To all whom it may concern:

Be it known that I, FREDERICK C. BEARD, of Aurora, in the county of Kane and State of Illinois, have invented certain new and useful Improvements in Double Drivers for Lathe Face-Plates; and I do hereby declare that the following is a full, clear, and exact description of the invention, which will enable others skilled in the art to which it appertains to make and use the same, reference being had to the accompanying drawings, and to letters of reference marked thereon, which form a part of this specification.

My improvements will be readily understood from the following description, aided by the drawings. The device is intended to be secured to the lathe-spindle similarly to the face-plate in general use, and while particularly suitable for axle-lathes or for pulley-lathes, it is useful for lathes generally.

The object of the invention is not only to drive the work (say a shaft) from two sides instead of from one side only, but also to make the driver self-adjusting, so that it will always bear equally against the two driving-points, and thus prevent chattering and trembling of the shaft.

Figure 1 is a front elevation; Fig. 2, a side elevation; Fig. 3, an end elevation; Fig. 4, a section through the line *x x* of Figs. 1 and 2; and Fig. 5, an elevation substituting a straight bar for the disk.

A is the face-plate, to be secured onto the lathe-spindle in the usual manner. It is provided with ears *b b*, which serve as journal-bearings for the double driver C, the opposite ends of which are journaled in these ears. This driver has two parallel dogs or driving-arms, *d d*, diametrically opposite each other, as shown, and against its central portion, *e*, bear the springs *e' e'*, which tend to keep the arms *d d* perpendicular to the face-plate.

It will be seen that when the driver is ap-

plied for use upon a lathe its two arms will not only drive at opposite sides of the center, but, as the arms are free to rock or vibrate together in either direction, they will automatically adjust themselves so as to bear equally upon the two driving-points, preventing all chattering or trembling of the work, while the springs serve to keep the driver in proper position and prevent its rocking violently in case the lathe should be run idle—*i. e.*, having nothing in it to drive.

This improvement is particularly adapted to "axle-lathes," and in fact to all lathes where the face-plate drives the work. For "pulley-lathes" it is especially suitable, because the projecting studs or dogs come in direct contact with the arms of the pulley, dispensing entirely with the customary dog, clamp, or carrier.

Instead of making the face-plate A circular in form, as shown, it may be in the form of a straight piece or bar, as shown in Fig. 5, the construction in all other respects being the same.

In some cases, if desired, the springs may be dispensed with, the rocker and its arms and the other parts remaining unchanged.

I claim—

1. A double driver for lathes, consisting of a bed or face-plate, combined with a yielding rocker journaled thereon and provided with driving arms or dogs, substantially as set forth.

2. The combination of a face-plate, A, having journal bearings or ears *b b*, the double driver C *d d*, and springs *e e'*, the combination being and operating substantially as shown and described.

FREDERICK C. BEARD.

Witnesses:

M. O. SOUTHWORTH,
C. C. SHIBLEY.